



NOVUS NW86 DRINKING FOUNTAIN

The disadvantage of "bubble jet" drinking fountains in general is that the outlet jet being in an exposed position is easily contaminated.

This disadvantage is easily overcome in the construction of our "NOVUS" fountain.

The water nozzle is located in a dished recess protected by a stainless steel cover plate which prevents access to the nozzle with the mouth.

Another disadvantage with the usual "upward jet" fountains is that the height of the jet of water is constantly changing as the mains pressure varies. This variation in main pressure obviously does not have the same effect on a downward jet.

The whole of the supply fitting being enclosed in the back structure prevents damage by misuse.

The control valve being fitted with a "toggle" lever makes operation very easy, a slight push or pull being all that is necessary. This is a point to be noted where very small children are concerned.

- **In Cast Iron With Exposed Fittings Chrome Plated**
- **White Plastic Coated**

AS NOW EXTENSIVELY ADOPTED BY LOCAL AND EDUCATION AUTHORITIES FOR USE IN SCHOOLS - PARKS - FACTORIES ETC

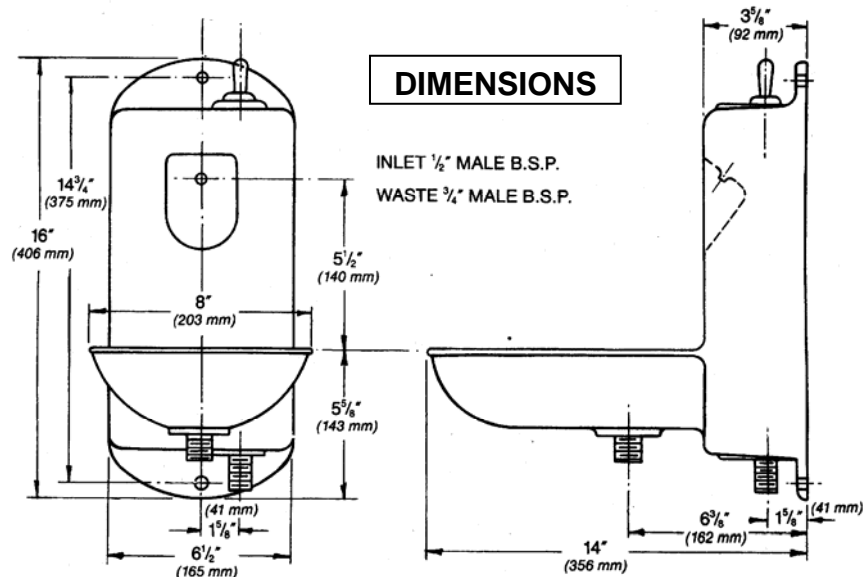

WEIGHT 26 lbs — 11.8 kg

50 Hastings Rd Croydon Surrey CR9 6BR